

## Reel Racks

RETAIN INSTRUCTIONS FOR FUTURE REFERENCE

---



### GENERAL SAFETY INFORMATION

Some parts may have sharp edges. CARE must be taken when handling various pieces to avoid injury. For safety, wear a pair of work gloves when assembling or performing any maintenance on units.

---

### LIMITED WARRANTY

Tennsco warrants goods purchased hereunder to be free of defects in materials and workmanship for a period of one (1) year from the date of shipment, hereunder. This warranty shall not apply in the event goods are damaged as a result of misuse, abuse, neglect, accident, improper application, modification or repair by persons not authorized by Seller, where goods are damaged during shipment, or where the date stamps on the goods have been defaced, modified or removed. UNLESS CONSIDERED UNENFORCEABLE OR UNLAWFUL UNDER APPLICABLE LAW:

- a. ALL IMPLIED WARRANTIES, INCLUDING BUT NOT LIMITED TO WARRANTIES OR MERCHANTABILITY AND FITNESS FOR A PARTICULAR PURPOSE ARE HEREBY EXCLUDED:
- b. BUYERS REMEDY, IF ANY, FOR ANY DEFECTIVE GOODS SHALL BE LIMITED TO A REFUND BY SELLER OR REPLACEMENT OF THE GOODS AT SELLER'S OPTION, AND SHALL IN NO EVENT INCLUDE DAMAGES OF ANY KIND, WHETHER INCIDENTAL, CONSEQUENTIAL OR OTHERWISE.

NO GOODS ACCEPTED FOR RETURN WITHOUT PRIOR APPROVAL. Seller shall have the right to inspect any goods claimed to be defective at Buyers place of business or require Buyer to return the goods to Seller for inspection on Seller's premises. Transportation charges covering returned goods will be borne by Seller only if such goods are proven to be defective, are covered by this warranty and are returned within the warranty period stated above.

---



**PROUDLY MADE IN THE U.S.A.**

Tennsco LLC., Dickson, TN 37056-1888 • (866) 446-8686

# ASSEMBLY OF REEL RACKING

**Tools Needed:** A rubber mallet for seating the shelf supports into the uprights.

Two people are recommended for assembly. Approximate assembly time: 20-30 minutes per section.

1. The reference numbers used throughout this sheet refer to the illustration on the back cover. This is to help you identify the various parts as they are mentioned.
2. Create a unit end by connecting two uprights (Ref. No. 1) with one of the front-to-back shelf supports (Ref. No. 2) by inserting the shelf support rivets into the bottom two keyhole slots of each upright using a rubber mallet to seat the upright securely in the keyhole slots. Then attach another front-to-back shelf support into the top two keyhole slots of each upright in the same manner as the bottom.

**NOTE: Be sure that the narrow end of the key hole slots are pointing downward, and the flat edge of the shelf support is facing up.**

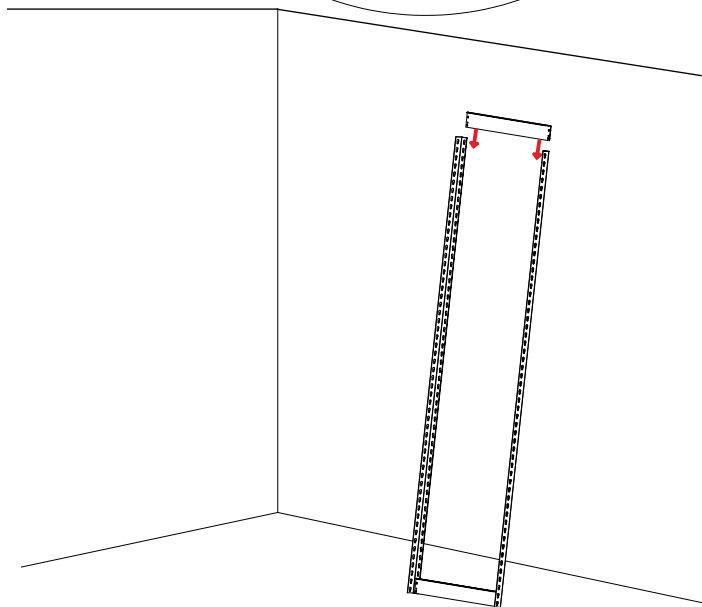
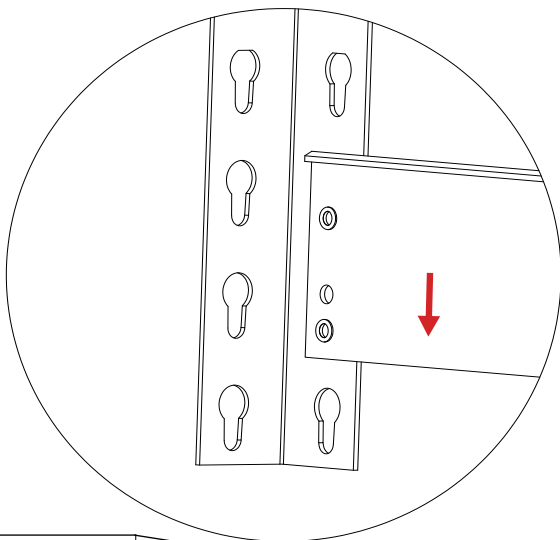

3. Assemble another unit end by repeating the directions in step 2. Be sure the shelf support rivets are seated in the bottom of the slots.

4. Connect two of the left-to-right shelf supports (Ref. No. 3) between the two assemblies, one on each side with angled corners facing toward each other. Be sure to use the two keyhole slots nearest the floor, as in step 2.

**NOTE: As in step two, make sure the flat edge of the shelf supports are facing upwards. If this has been done correctly, there would now be a flat surface around all four edges. If any edges have an upward facing angled edge, the support has been inserted upside down.**

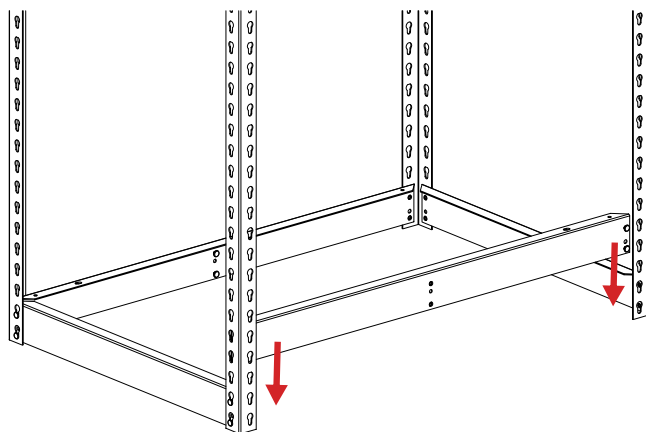

**NOTE: Be sure that the support rivets are seated in the bottom of the slots of the uprights securely.**

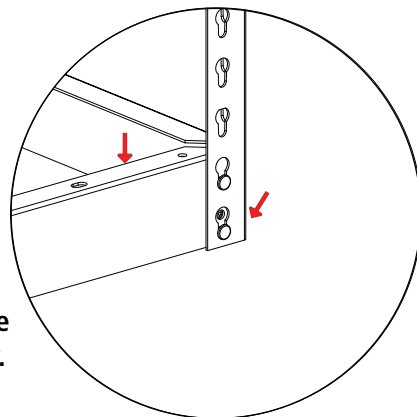

5. Finish installing the remaining left-to-right shelf supports and front-to-back shelf supports around the top of the unit as in step 4.

6. After building the framework, place a rod support (Ref. No. 4) at the desired reel levels. Be sure all the supports are fully seated. Once these support levels are placed, the reel rods can be added.

**NOTE:** Be sure that the "V" shaped slots are facing upward as show below.

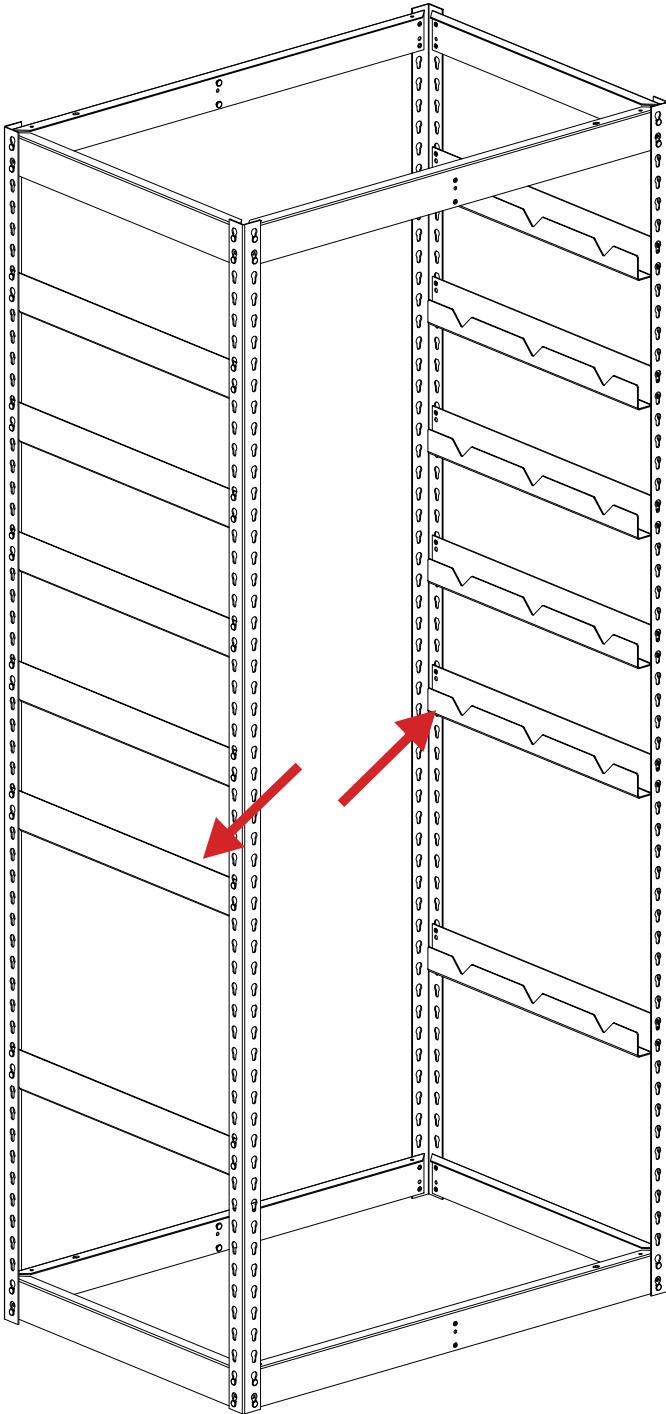

7. Rest the reel rod (Ref. No. 5) in the notch of the rod support as shown below. Each rod support level can hold up to three reel rods. Each unit comes with six reel rods.

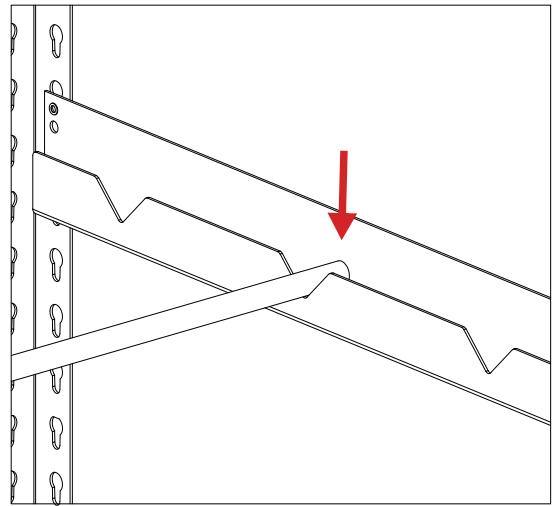

8. Your unit is now finished and ready for use.

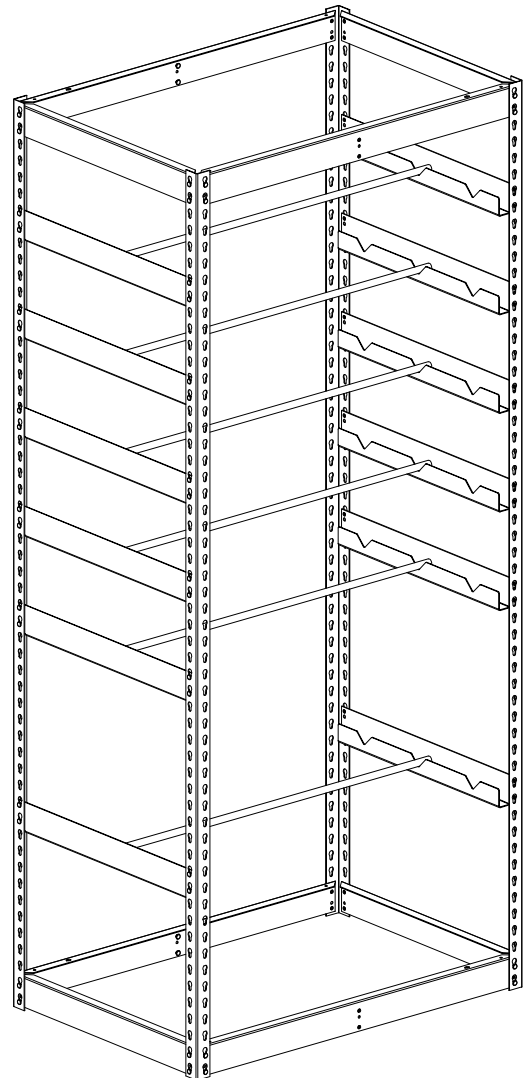

# REPLACEMENT PARTS

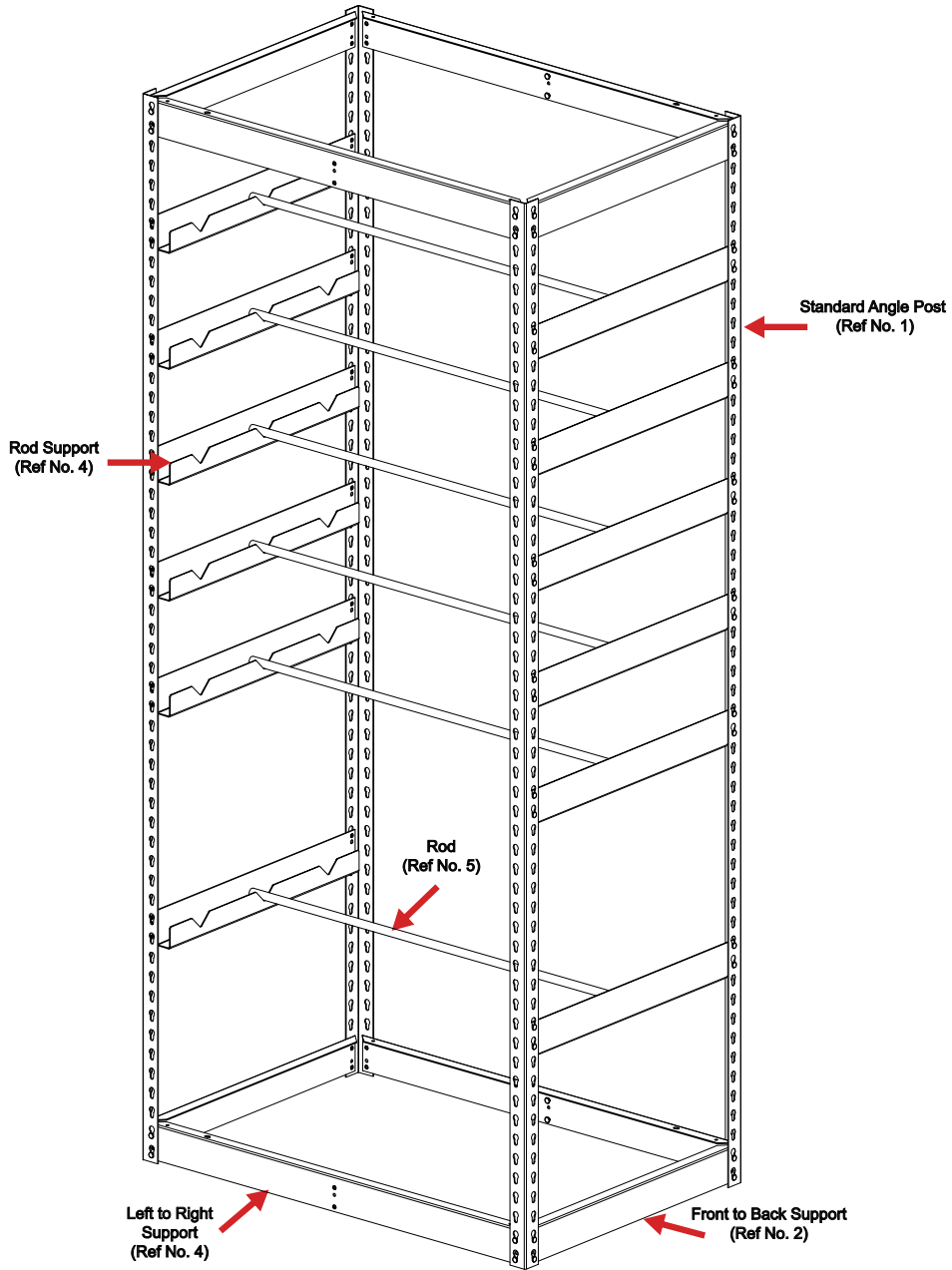

REF. NO.	DESCRIPTION	PART NUMBERS	QTY.	
			36x24 UNIT	48x24 UNIT
1	Standard Angle Post	EUR-84	4	4
2	Front to Back Support	LRA-24	4	4
3	Left to Right Support	LRA-36	4	--
	Left to Right Support	LRA-48	--	4
4	Rod Support	LRJ-24	12	12
5	Rod	045CR-MGY	6	--
	Rod	055CR-MGY	--	6

Tennsco makes every effort to ensure that all units ship complete with all parts and arrive undamaged. However, should your unit contain missing or damaged parts, please contact your purchase location.